



# **Saline Water Threshold Level that Maximizes Grain Yield Production and Minimizes Sodium Accumulation for Salinity Stress-sensitive and Tolerant Wheat Cultivars**

**Sabah Morsy<sup>1</sup>, Ibrahim S. Elbasyoni<sup>1\*</sup> and Stephen Baenziger<sup>2</sup>**

<sup>1</sup>*Department of Crop Science, Faculty of Agriculture, Damanhour University, Elbhera, 22516, Egypt.*

<sup>2</sup>*Department of Agronomy and Horticulture, University of Nebraska-Lincoln, Lincoln, NE 68583, USA.*

## **Authors' contributions**

*This work was carried out in collaboration among all authors. Author SM participated in designing the study, collecting the data, reviewing and approving the final version. Author ISE participated in designing the study, data collection, designing the experiment and data analysis, writing the first draft and approving the final version. Author SB participated in designing the study, review and approve the final version.*

## **Article Information**

DOI: 10.9734/AJRCS/2021/v6i130107

### Editor(s):

(1) Dr. Ahmet Esen Çelen, Ege University, Turkey.

### Reviewers:

(1) Dallahi Youssef, Cadi Ayyad University, Morocco.

(2) Ali Omrani, Ardabil Agricultural and Natural Resources Research and Education Center (AREEO), Iran.

Complete Peer review History: <http://www.sdiarticle4.com/review-history/65526>

**Original Research Article**

**Received 02 December 2020**

**Accepted 09 February 2021**

**Published 20 February 2021**

## **ABSTRACT**

Saline irrigation is one of the approaches that was developed to address the freshwater gap in many regions around the world. This experiment was conducted in two growing seasons under open field conditions in pots. In addition to the control (0.5 dSm<sup>-1</sup>), three levels of saline water, i.e., 5.0, 7.0, and 9 dSm<sup>-1</sup> were used to irrigate ten commercially grown Egyptian wheat cultivars. The number of days to flowering, plant height, fertile tillers, grain weight per spike, number of kernels per spike, and grain yield were measured. Furthermore, Na<sup>+</sup>, K<sup>+</sup>, Ca<sup>+2</sup>, Mg<sup>+2</sup>, and Cl<sup>-</sup> were also measured. The objectives of the current study were to (a) estimate the quantitative impact of various levels of saline irrigation water on physio-agronomical performance of commercially grown wheat cultivars; (b) highlight the importance of using salinity stress tolerant wheat cultivars in a scenario where they grow beside salinity stress-sensitive ones and are irrigated with multiple levels of saline water.

\*Corresponding author: E-mail: [ibrahim.salah@agr.dmu.edu.eg](mailto:ibrahim.salah@agr.dmu.edu.eg), [ielbasyoni2@unl.edu](mailto:ielbasyoni2@unl.edu), [iseunl19@gmail.com](mailto:iseunl19@gmail.com);

Salinity stress tolerant wheat cultivars tend to maintain higher levels of  $K^+$ ,  $Ca^{+2}$ , and  $Mg^{+2}$ , compared to the sensitive ones. Overall, the average performance of the salinity stress-tolerant cultivars across the levels of saline water used was 26.5% higher than the sensitive ones for grain yield. Our results also indicated that  $6.25 \text{ dSm}^{-1}$  is the maximum saline water that can be used to irrigate the sensitive wheat cultivars. In which  $6.25 \text{ dSm}^{-1}$  is the salinity level that maximizes grain yield, the number of fertile tillers, and  $K^+$  concentration while minimizing  $Na^+$  accumulation in plants. For the same reasons,  $9 \text{ dSm}^{-1}$  was defined as the salinity threshold for the salinity stress-tolerant cultivars.

**Keywords:** Salinity tolerance; K/Na ratio; soil salinization;  $K^+$ ;  $Ca^{+2}$ ;  $Mg^{+2}$  deficiency.

## 1. INTRODUCTION

Agricultural sustainability is threatened by increased soil salinization [1] which reduces both the productivity and availability of land for agriculture. Soil salinization is the most devastating abiotic stress and causes substantial yield losses [1]. Unfortunately, soil salinization is projected to expand as a result of global warming, in which sea level and temperature will rise, which will increase the rate of evaporation [2]. Although wheat (*Triticum aestivum* L.) is moderately tolerant to salinity stress, it loses about 50% of its yield when grown in saline soil or irrigated with saline water [3,4]. Furthermore, the arid and semiarid regions, about 40% of the world's land, are being affected by soil salinization, which will increase food shortages and insecurity by reducing wheat grain yield [5].

Among other middle eastern and north African countries, Egypt suffers from increasing soil salinity problems [6]. Moreover, the northern part of the Nile Delta in Egypt is an example of the arid regions that suffer from increasing soil salinization [7]. Climate conditions, using saline underground water and irrigation without deploying an efficient drainage system, led to soil salinization in several regions in Egypt [8]. Around 33% of the cultivated land is currently saline due to low precipitation (< 25 mM annual rainfall) and irrigation with saline water [9]. Furthermore, in several parts of Egypt, and due to freshwater shortage, farmers are using underground water with an EC of more than three  $\text{dSm}^{-1}$  and in some cases, up to  $8 \text{ dSm}^{-1}$  [10,11,8].

The development of salt-tolerant genotypes proved to be the most effective and economical approach to alleviate salinity stress problems [12]. Plant tolerance to salinity stress is a quantitative trait implying that it involves several genetic mechanisms affecting morphological and physiological traits that regulate the plant's response to the saline growth environment [5].

Among the morphological and physiological traits for salinity stress tolerance are osmotic tolerance and toxic ion exclusion [13,5]. During long-term exposure to salinity, stressed plants experience ionic stress and toxicity, which can result in a reduction in photosynthesis to support continued growth [14]. High concentrations of salts in the soil also reduce the roots' capacity to take up water by increasing the ionic strength of the soil solution and interfere with nutrients uptake [15,1]. Ionic stress, mainly caused by  $Na^+$  accumulation, causes early senescence of mature leaves, chlorosis, and necrosis. Furthermore, the excessive accumulation of  $Na^+$  in plants might disrupt protein synthesis, interfere with overall enzyme activities, and causes cell death [1,3]. Thus,  $Na^+$  exclusion has a vital role in salinity stress tolerance [16].

Salinity stress causes several physiological changes, including cell membrane interruption, nutrient imbalance, inhibiting the cell's ability to detoxify reactive oxygen species (ROS), change the antioxidant enzymes pattern and decreased photosynthetic activity [17,18,19,16,20,14]. Salinity stress tolerance is a complicated process controlled by several small effect genes and often confounded by differences in plant morphology and physiological stages [21]. Salinity stress, particularly during the reproductive and grain-filling stages, significantly reduced grain yield [22,23]. Hence, yield and yield components have also been considered as abiotic stress tolerance indicators for several crops such as wheat [24]. Finally, fertile tillers and the number of tillers per plant have also been used to measure salinity stress tolerance [24]. Generally, the use of several agromorphological and physiological traits were found to be reliable indicators to study stress tolerance and identify tolerant genotypes in various crops [25,8].

Imposing salinity stress to study its impact or to identify tolerant genotypes play a crucial role in screening cultivars for salinity tolerance [23].

Whereas salinity stress might occur where soils are naturally high in salts, it can also occur where salty underground water is being used in irrigation [26]. For example, in recent years, saline water has been utilized to cope with the freshwater shortage in several world regions [27]. Thus, to understand the impact of using saline water on soil and plant, it is essential to use irrigation water with appropriate salinity levels to identify genotypes with better grain yield under stress [28]. Several approaches were used to evaluate wheat genotypes for salinity stress tolerance, i.e., using saline soils or water under the open field conditions or indoors [29]. Despite the merits of salinity stress evaluation under saline soil in the open field, it is quite challenging [30]. First of all, it requires a large volume and continuous supply of saline water with a fixed salinity level. Second, it might be feasible to find a water source with a specific salinity level. However, it is hard to find several water sources within the same environment with different salinity levels to understand the trends with increasing salinity. Third, using high saline water (8 dSm<sup>-1</sup> or higher) will increase the soil salinization process and degrade the experimental field. Fourth, in addition to the fact that most soils have heterogenous vertical and horizontal salinity levels, the occurrence of other stresses such as drought and heat stress might be confounded with salinity stress. These challenges limited the success of using saline water as a source of salinity stress evaluation under the open field conditions to identify salinity stress-tolerant genotypes [5]. Thus, using saline water in irrigation should be evaluated in contained soil conditions.

Evaluation for salinity stress indoors, i.e., laboratory or greenhouses, is another approach that was thought to be advantageous to the open field evaluation because of the controlled environmental conditions and the ability to control the salinity levels in irrigation water [31]. However, the greenhouse or controlled conditions might not genuinely represent the field conditions [32]. Thus, salinity stress-tolerant genotypes identified under indoor conditions may not be useful in the field [33,34]. Contained soil approach evaluation under the open field conditions is simple, efficient, and eliminates the risk of soil salinization due to using high levels of saline water to irrigate crops grown in the open field [35,28]. Furthermore, using contained soil evaluation under open field conditions facilitates studying the response of plants to various levels of saline water while they are being exposed to

natural production variables, i.e., sunlight and radiation, wind, and evapotranspiration.

In the current experiment, sensitive, moderately tolerant, and tolerant wheat cultivars were evaluated. Among these cultivars, Sakha8, released by the agriculture research center (ARC), Egypt, was used as known salinity stress tolerant cultivar [36,29]. Munns et al., (2005) recommend using Sakha8 to understand and reveal mechanisms that can be useful in developing future salinity stress-tolerant wheat genotypes. Furthermore, Sakha93 and Misr2 are more recent releases and are also known to be salinity stress-tolerant cultivars [37,38]. In contrast, Sakha61, Sakha94, Gemmiza9 cultivars were previously found to be sensitive to salinity stress [37,39,40]. Furthermore, Giza164 and Gemmiza10, Sides1, and Giza168 were found to be sensitive to moderately tolerant cultivars to salinity stress [8,37,38]. This study shows for the first time the agronomical and physiological penalties of using saline water in irrigating tolerant and sensitive wheat cultivars. Furthermore, it also shows the salinity threshold level that maximizes grain yield, the number of fertile tillers, and K<sup>+</sup> while minimizing Na<sup>+</sup> accumulation for the salinity stress-sensitive and tolerant wheat cultivars.

Therefore, the main objectives of the current experiment were to use commercially grown and salinity stress-sensitive, moderately tolerant, and tolerant wheat cultivars (a) to estimate the quantitative impact of various levels of saline irrigation water on K/Na ratio, Ca<sup>+2</sup>, Mg<sup>+2</sup>, Cl<sup>-</sup>, number of days to flowering, plant height, fertile tillers, grain weight per spike, number of kernels per spike, and grain yield; and (b) to highlight the importance of using salinity stress tolerant wheat cultivars in farming by growing them next to salinity stress-sensitive cultivars while irrigating with multiple levels of saline water.

## 2. MATERIALS AND METHODS

### 2.1 Experimental Conditions

The experiment was conducted in pots placed on an open field in two consecutive growing seasons (2017/2018 and 2018/2019; hereafter referred to by their harvest season, 2018, and 2019) in Elbostan experimental farm ((30°46'46" N, 30°82'32" E), Damanhour University, ElBehira governorate, Egypt. The soil in Elbostan is classified as loamy soil, typic Torripsamments [41]. The soil was collected from Elbostan farm and carefully mixed, then a soil sample from the

mixed soil was bagged and labeled (for pre-planting soil analysis, Table 1). The rest of the soil was mixed with the recommended pre-plant fertilizers in which each kilogram of soil received 0.1 g N, 0.063 gm P<sub>2</sub>O<sub>5</sub>, and 0.06 g K<sub>2</sub>O. Then, 8 kg air-dried mixed soil was packed to their density of (1.39 Mgm<sup>-3</sup>) in free-draining plastic pots of 1125 cm<sup>3</sup> volume. Ten uniform seeds were surface sterilized by dipping in 0.5% hypochlorite solution for 20 min, then thoroughly rinsed with distilled water followed by drying and directly planted in each pot. All pots were irrigated to the field capacity using normal irrigation water (0.5 dSm<sup>-1</sup>). One week after planting, the seedlings were thinned to seven uniform seedlings per pot. An additional 0.2 g N per pot was applied when the third leaf on the plant was expanded, and another 0.2 g N per pot was used at the jointing stage. The pre-planting and post-harvest soil analyses were conducted according to Page (1980) and Klute (1986) (Table S1).

## 2.2 Plant Materials and Experimental Design

Ten newly developed and commercially grown wheat cultivars were studied (Table S2). Seeds of these cultivars were obtained from the Agricultural Research Center (ARC), Egypt. A split-plot arrangement in a complete block design with three replicates was used, NaCl concentrations were randomly assigned to the main plots, while cultivars were randomly assigned to the subplots.

## 2.3 Agronomics and Saline Water Management

Trials were conducted under weed-free conditions and in both growing seasons. The cultivars were sown on November 20, 2017, and November 15, 2018, during the first and second growing seasons, respectively. Three pots were assigned to each treatment within each replicate. All pots were watered using normal irrigation water used in the region (0.5 ± 0.015 dSm<sup>-1</sup>) until the seedlings had emerged entirely and had up to three leaves (approximately 20 days). From that stage to maturity, pots were watered to the field capacity with the assigned saline water levels, and soil salinities were monitored periodically to ensure no salt accumulation in the root zone. Saline solutions were prepared using NaCl at three concentrations, i.e., 5.0, 7.0, and 9 dSm<sup>-1</sup>. For each pot, the number of days to flowering (NDF) was recorded visually as the

number of days from sowing to anther exertion. Plant height (cm) was measured after physiological maturity, as the distance from the soil surface to the spike's tip, excluding awns. During the late stages of grain filling, the number of fertile tillers (e.g., those having grains) were counted. Directly before harvest, grain weight per spike, and the number of kernels per spike were measured. All plants in the three pots that were assigned for each treatment within each replicate were mass harvested together and left to air dry in an open bag. After three days, plants from each treatment were threshed manually, bagged, and weighted. Then the average of the three pots was calculated and used as a single experimental unit per replicate as grams pot<sup>-1</sup>.

## 2.4 Mineral Measurements

Flag leaves from each experimental unit were sampled when plants reached full maturity. Approximately 0.4 gm of leaves were dried and ground into a fine powder. Then, the dry powder was digested and prepared for the mineral analysis following methods described by Krishnasamy et al., [42]. The digested filtrate was then used to measure the total cations of Na<sup>+</sup>, K<sup>+</sup>, Ca<sup>+2</sup>, and Mg<sup>+2</sup> by an inductively coupled plasma atomic emission-spectrometry (ICP-AES) (Varian 730-ES, Varian Inc., California, USA). In comparison, the Chloride concentration was estimated in a subsample of the digested extracts using a Cl<sup>-</sup> analyzer (Model 926, Sherwood Scientific, Cambridge, UK).

## 2.5 DNA Extraction and Salinity Tolerance Microsatellites

The total genomic DNA was extracted from 200 mg of fresh leaves during the seedling stage. DNA extraction kit (Promega, USA) was used, and the manufacturer's instructions were followed. The DNA concentration of each sample was measured using a spectrophotometer at a wavelength of 260 and 280 nm using a CARY 50 probe UV-visible spectrophotometer (Varian, CA, USA). The DNA quality was confirmed by running 5 µl eluted DNA on a 0.8% agarose gel. In the current experiment ten SSR markers were used, i.e., *cslinkNax2*, *Xgwm312*, *Xbarc128*, *Xwmc773*, *Xgwm674*, *Xbarc159*, *Xbarc273*, *Xcfd9*, *Xcfd46* and *XWmc170*. The primer sequences, linkage map location, the specific band (bp) location, and the amplification requirements for the SSR markers were obtained from the Grain Genes website (<https://wheat.pw.usda.gov/cgi-bin/GG3/browse.cgi?class=marker>)

## 2.6 Statistical Analysis

Analysis of variance was carried out using SAS 9.4 (SAS v9.4; SAS Institute Inc., Cary, NC, USA), by fitting the following model [43]:

$$Y_{ijlm} = \mu + E_i + EB_{(ij)} + S_j + EBS_{(ijl)} + G_m + EG_{im} + SG_{lm} + ESG_{ilm} + \varepsilon_{ijlm}$$

Where  $Y_{ijlm}$  is the response measured on the  $ijlm$  experimental unit or pot,  $\mu$  is the overall mean,  $E_i$  is the effect of  $i^{th}$  growing season,  $EB_{(ij)}$  is  $j^{th}$  block nested within  $i^{th}$  growing season,  $S_j$  is the effect of the  $j^{th}$  salinity level,  $EBS_{(ijl)}$  is the interaction between  $i^{th}$  salinity level and  $j^{th}$  replicates within  $i^{th}$  growing season as an error term for the growing season, and salinity level.  $G_m$  is the effect of  $m^{th}$  cultivar,  $EG_{im}$  is the interaction effect between  $i^{th}$  growing season and  $G^{th}$  cultivar.  $SG_{lm}$  is the interaction effect between  $l^{th}$  salinity level and  $G^{th}$  cultivar.  $ESG_{ilm}$  is the interaction between  $i^{th}$  growing season,  $l^{th}$  salinity level, and  $G^{th}$  cultivar, and  $\varepsilon_{ijlm}$  is the experimental error.

Homogeneity of variance across the growing season was tested following Bartlett's Test [44]. Combined analyses of variance were performed among traits with a homogeneous variance, as outlined by Cochran and Cox [45]. Means were compared using honestly significant difference (Tukey's HSD) at  $P$ -value < 0.05, according to Gomez and Gomez [46].

Genetic correlations among traits combined across growing seasons were estimated using META-R software [47]. Two genetic correlation matrices were calculated using a randomized complete block design (RCBD) model in META-R [47]. The first matrix was among traits that were measured under control (0.5 dSm<sup>-1</sup>) and the second was among the traits that were measured under 9 dSm<sup>-1</sup>. Similarly, two genetic correlation among cultivars were estimated under control (0.5 dSm<sup>-1</sup>), and under 9 dSm<sup>-1</sup>. The correlation matrices were then converted into Euclidean distances following Ward's method [48] and dendrograms were constructed to examine the relationships among traits and cultivars under 0.5 dSm<sup>-1</sup>, and 9 dSm<sup>-1</sup>.

## 3. RESULTS

Normal distribution and homogeneity of variance for the number of days to flowering, plant height, number of fertile tillers, the number of kernels per spike, the grain weight per spike, grain yield, Na<sup>+</sup>, Cl<sup>-</sup>, Ca<sup>+2</sup>, Mg<sup>+2</sup>, K<sup>+</sup>, and K/Na ratio across growing seasons ( $p$ -values >0.05) were

observed. Therefore, a combined analysis of variance was conducted. The results of the combined analysis of variance are presented in Table S3. A highly significant effect ( $p$ -value < 0.001) for salinity stress (S) and cultivars for all traits were observed. Moreover, cultivars × S interaction were highly significant for all traits. Furthermore, salinity levels, cultivars, and salinity × cultivars interaction also significantly affected Na<sup>+</sup>, Cl<sup>-</sup>, Ca<sup>+2</sup>, Mg<sup>+2</sup>, K<sup>+</sup>, and K/Na ratio (Table S4).

### 3.1 Impact of Saline Irrigation on the Agro-physiological Traits

The values of the studied traits averaged over all cultivars were generally higher in the control conditions (0.5 dSm<sup>-1</sup>) compared to the saline ones (5,7 or 9 dSm<sup>-1</sup>). The reduction was greater with increasing salinity levels for all agronomic traits (Fig. 1). Thus, we will focus on presenting the impact of the highest salinity level (9 dSm<sup>-1</sup>) compared to the control.

Table S5 illustrated that as salinity has risen from 0.5 to 9 dSm<sup>-1</sup>, the number of days to flowering, plant height, grain yield, the number of tillers per plant, the number of kernels per spike and grain weight per spike declined by 25.5, 45, 63.9, 66.9, 67 and 62.5%, respectively. For the number of days to flowering, the smallest reduction (20.7%) of increasing salinity was observed in Gemmiza10, while the largest reduction (28.3%) was in Sakha61. The reduction in plant height ranged from 48% for Gimmiza7 and Misr2 (most affected), to 40 % for Gimmiza9 (least affected) (Table S5). The highest grain yield (11.0 grams) was recorded for Gimmiza10 under control conditions (0.5 dSm<sup>-1</sup>). However, Gimmiza10 had the greatest reduction (77.5 %). The grain yield of any cultivar decreased by the rise in salinity levels from 0.5 to 9 dSm<sup>-1</sup>. For grain yield, Sakah8 (38.2%), Misr2 (39.4%), and Sakha93 (49.4%) were the least affected cultivars due to salinity stress. Similarly, Sakah8 (36.3%), Sakha93 (39.5%), and Misr2 (53.5%) were the least affected cultivars by salinity stress for the reduction in the initial number of tillers. By comparison, Sakha61 lost 82.1% of its initial number of tillers due to the high salinity level. The smallest reduction (47%) for the number of kernels per spike was recorded for Sakaha8, while the greatest reduction (78% ) were for Gemmiza10 and Gimmiza7 (Table S5). Similarly, the smallest reduction (18.8 %) and the greatest reduction (88.6%) for grain weight per spike were found in Misr2 and Giza164, respectively.

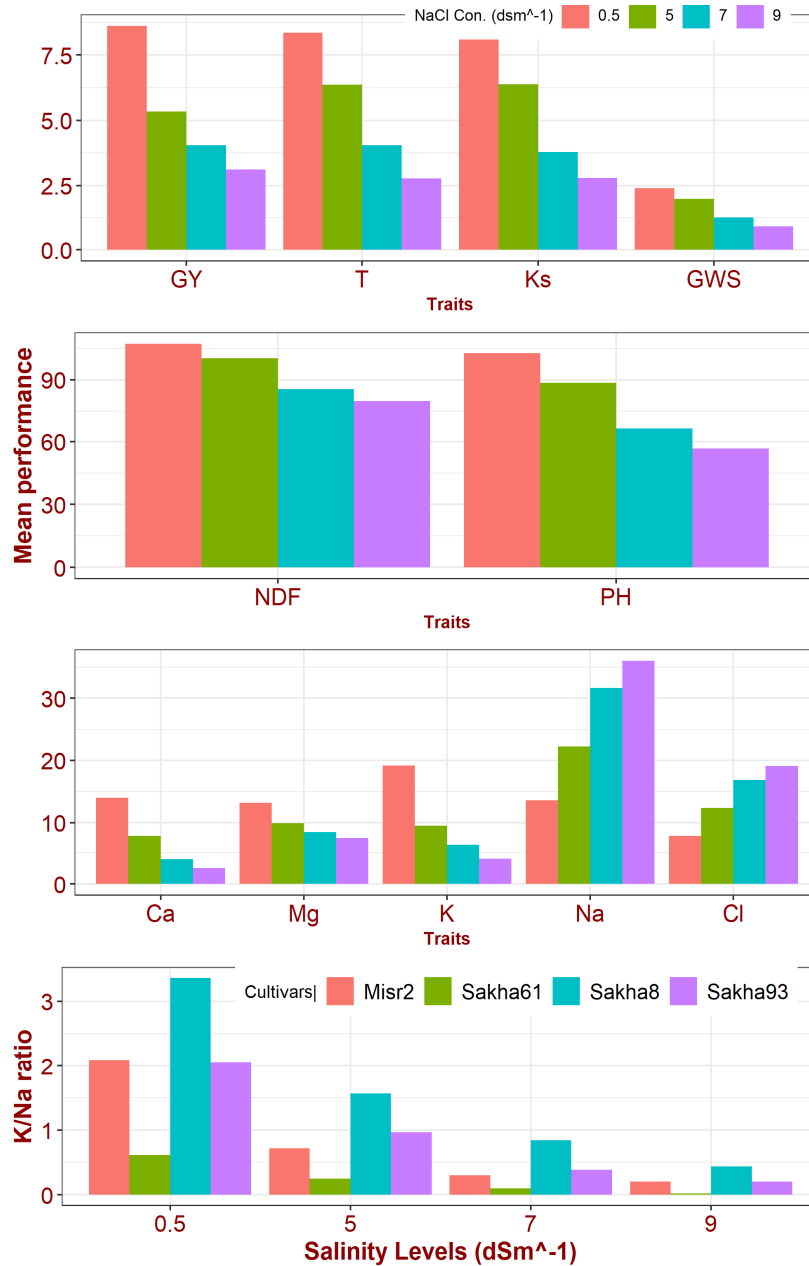

**Fig. 1. The effect of saline irrigation levels (dSm<sup>-1</sup>) on the number of days to flowering (NDF), plant height (PH), grain yield (GY), number of tillers (T), the number of kernels per spike (KS), grain weight per spike (GWS), Ca, K, Mg, Na, Cl and K/Na ratio across growing seasons**

### 3.2 Impact of Saline Water on Na<sup>+</sup>, Ca<sup>+2</sup>, Mg<sup>+2</sup>, K<sup>+</sup>, and Cl<sup>-</sup> Uptake

Our results indicated that the concentration of NaCl in the irrigation water had a measurable impact on Na<sup>+</sup>, Ca<sup>+2</sup>, Mg<sup>+2</sup>, K<sup>+</sup>, and Cl<sup>-</sup> uptake (Fig. 2 & Table S6). Substantial increases in Na<sup>+</sup>, Cl<sup>-</sup> was observed as would be expected, in which Na<sup>+</sup> was increased from 13.85 to 31.95 mg g<sup>-1</sup> as

the NaCl concentration increased from 0.5 to 9 dSm<sup>-1</sup>. Moreover, as salinity increase from 0.5 to 9 dSm<sup>-1</sup>, Cl<sup>-</sup> was increased from 7.4 to 18.9 mg g<sup>-1</sup>. However, Ca<sup>+2</sup>, Mg<sup>+2</sup>, and K<sup>+</sup> decreased as the salinity increased. Ca<sup>+2</sup> decreased from 14 mg g<sup>-1</sup> under 0.5 dSm<sup>-1</sup> to 2.6 mg g<sup>-1</sup> under 9 dSm<sup>-1</sup>. Similarly, Mg<sup>+2</sup> was reduced from 13.2 to 7.6 mg g<sup>-1</sup> and K<sup>+</sup> was decreased from 19.2 to 4.1 mg g<sup>-1</sup>, as salinity increased from 0.5 to 9

dSm<sup>-1</sup>. Finally, K/Na ratio was reduced as salinity increased, in which it was reduced from 1.7 to 0.1 as salinity increased from 0.5 to 9 dSm<sup>-1</sup> (Table S6).

The highest Na<sup>+</sup> and Cl<sup>-</sup> concentrations measured in the flag leaf averaged over the four salinity levels were observed in cultivar Sakha61 (Table S6). While the lowest Na<sup>+</sup> concentrations were found in Sakha93, followed by Misr2. Sakha93 also had the lowest Cl<sup>-</sup> concentration, followed by Sakha8 and Gimmiza9. Moreover, Sakha61 had the lowest Ca<sup>+2</sup> concentration, while Misr2 had the highest Ca<sup>+2</sup> concentration. Sakha61 had the lowest K<sup>+</sup> concentration. The highest Mg<sup>+2</sup> concentration was observed in Misr2, while Sakha61 recorded the lowest Mg<sup>+2</sup> concentration. Furthermore, Sakha8, Sakha93, and Misr2 had the highest

K/Na ratios, but Sakha61 had the smallest K/Na ratio (Table S6).

The response for Misr2, Sakha8, Sakha93, and Sakha61 were different in terms of Na<sup>+</sup>, Ca<sup>+2</sup>, Mg<sup>+2</sup>, K<sup>+</sup>, Cl<sup>-</sup> and K/Na ratio (Fig. 2). Overall, Fig. 2 shows the pattern of response to increasing salinity for Misr2, Sakha8, Sakha93, and Sakha61. Sakha61 had the highest concentrations of Na<sup>+</sup>, and Cl<sup>-</sup> for 0.5, 5, and 7 dSm<sup>-1</sup> salinity levels. Sakha8 had the highest Ca<sup>+2</sup>, Mg<sup>+2</sup> concentrations measured under 5 dSm<sup>-1</sup> of salinity level. Misr2 had the highest Ca<sup>+2</sup> concentration when irrigated with non-saline water. Under salinity conditions, Sakha8 and Sakha93 had the highest K<sup>+</sup> concentrations and K/Na ratios, while under non-saline conditions, Misr2 had the highest K<sup>+</sup> concentration.

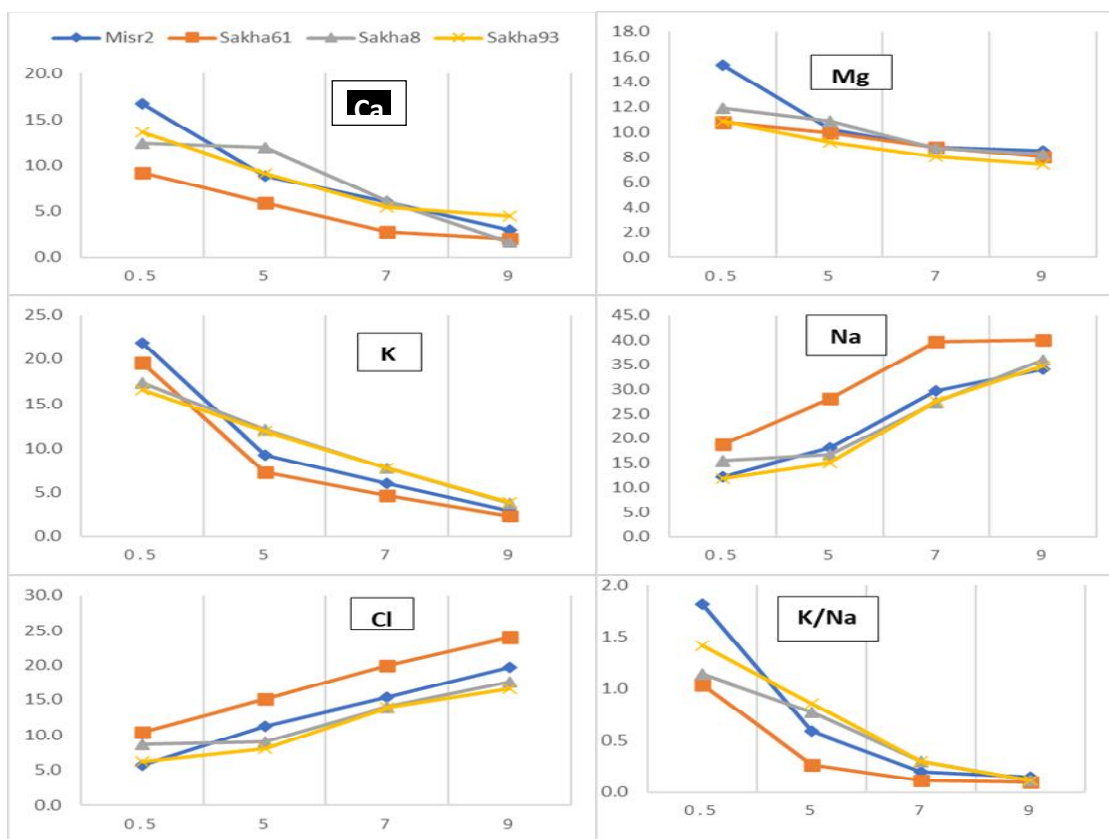

Fig. 2. The effect of NaCl concentrations (dSm<sup>-1</sup>) in the irrigation water on Na<sup>+</sup>, Ca<sup>+2</sup>, Mg<sup>+2</sup>, K<sup>+</sup>, and Cl<sup>-</sup> uptake (mg g<sup>-1</sup> dry weight) by Sakha61 (sensitive), Sakha8, Misr2 and Sakha93 (tolerant)

### 3.3 Physio-agronomical Correlation with $\text{Na}^+$ , $\text{Ca}^{+2}$ , $\text{Mg}^{+2}$ , $\text{K}^+$ , and $\text{Cl}^-$ Uptake

#### 3.3.1 Under non-saline irrigation (control; 0.5 $\text{dSm}^{-1}$ )

The dendrogram grouping based on genetic correlations among the studied traits measured under the control conditions (0.5  $\text{dSm}^{-1}$ ) is illustrated in Fig. 3.  $\text{Cl}^-$ ,  $\text{Mg}^{+2}$ , plant height, and  $\text{Na}^+$  were grouped into one group. Grain weight per spike,  $\text{K}^+$ , number of tillers, grain yield, and number of kernels per spike were arranged into another group.  $\text{K}/\text{Na}$  ratio,  $\text{Ca}^{+2}$ , and the number of days to flowering were grouped into a third group.

A significant positive genetic correlation between  $\text{Ca}^{+2}$  and  $\text{Mg}^{+2}$ ,  $\text{K}^+$ ,  $\text{K}/\text{Na}$ , plant height, grain yield, and kernels per spike. In contrast,  $\text{Ca}^{+2}$  was negatively correlated with  $\text{Na}^+$  and  $\text{Cl}^-$  (Table S7).  $\text{Mg}^{+2}$  was positively correlated with  $\text{K}^+$ ,  $\text{K}/\text{Na}$  ratio, plant height, grain yield, and kernels per spike.  $\text{Mg}^{+2}$  was negatively correlated with  $\text{Na}^+$  and  $\text{Cl}^-$ .  $\text{K}^+$  was positively correlated with  $\text{K}/\text{Na}$ , plant height, grain yield, and kernels per spike. In contrast,  $\text{K}^+$  was negatively correlated with  $\text{Na}^+$  and  $\text{Cl}^-$ .  $\text{Na}^+$  was positively correlated with  $\text{Cl}^-$  and negatively correlated with  $\text{K}/\text{Na}$  and the number of days to flowering (Table S7).  $\text{K}/\text{Na}$  was positively correlated with grain yield. The number of days to flowering was negatively correlated with the number of fertile tillers and the number of kernels per spike. Plant height was positively correlated with grain yield and the number of kernels per spike. Grain yield was positively correlated with the number of fertile tillers and kernel weight per spike. The number of fertile tillers was positively correlated with the number of kernels per spike (Table S7).

#### 3.3.2 Under saline irrigation (9 $\text{dSm}^{-1}$ )

Under salinity stress, all parameters measured formed three main groups (Fig. 3); the first group contained  $\text{Cl}^-$ ,  $\text{Na}^+$ , Grain weight per spike and the number of days to flowering. The second group included  $\text{K}^+$ ,  $\text{Ca}^{+2}$ ,  $\text{Mg}^{+2}$ , grain yield, and  $\text{K}/\text{Na}$  ratio. The third group contained the number of kernels per spike, plant height and the number of fertile tillers (Fig. 3).  $\text{Ca}^{+2}$  was positively correlated with  $\text{K}^+$ ,  $\text{K}/\text{Na}$  ratio, the number of days to flowering, grain yield, the number of fertile tillers, kernel per spike, and grain weight per spike. Furthermore,  $\text{Ca}^{+2}$  was negatively correlated with  $\text{Na}^+$ ,  $\text{Cl}^-$  and plant height (Table S7).  $\text{Mg}^{+2}$  was negatively correlated with  $\text{Cl}^-$ .  $\text{K}^+$

was positively correlated with  $\text{K}/\text{Na}$  ratio, the number of days to flowering, grain weight, the number of fertile tillers, number of kernels per spike, and grain weight per spike. At the same time,  $\text{K}^+$  was negatively correlated with plant height and  $\text{Na}^+$ .  $\text{Na}^+$  was positively correlated with  $\text{Cl}^-$  and plant height (Table S7).

$\text{Na}^+$  was negatively correlated with  $\text{K}/\text{Na}$  ratio as would be expected with  $\text{Na}$  being in the denominator, the number of days to flowering, grain yield, number of fertile tillers, number of kernels per spikes and grain weight per spike.  $\text{Cl}^-$  was negatively correlated with  $\text{K}/\text{Na}$  ratio (Table S7).  $\text{K}/\text{Na}$  ratio was positively correlated with the number of days to flowering, grain yield, the number of fertile tillers, number of kernels per spike, and grain weight per spike (Table S7). The number of days to flowering was positively correlated with grain yield, the number of fertile tillers, the number of kernels per spike and grain weight per spike, but it was negatively correlated with plant height. Plant height was negatively correlated with grain yield, the number of fertile tillers, the number of kernels per spike and grain weight per spike. However, grain yield was found to be positively correlated with the number of fertile tillers, the number of kernels per spike, and grain weight per spike (all well-known components of grain yield). The number of fertile tillers was positively correlated with the number of kernels per spike and grain weight per spike. The number of kernels per spike was positively correlated with grain weight per spike (Table S7).

### 3.4 Cultivars Performance using Physio-agronomical Traits

Physiological and agro-morphological traits were used to cluster the studied cultivars under saline and non-saline irrigation. The dendrogram obtained using the parameters measured under non-saline irrigation indicated that the cultivars could be clustered into three major groups. The first group contained Sakha93, Sakha8, Sakha61, and Giza164. The second group included Saka94, Gimmiza7, Misr2, and Gemmiza10. The third group included Giza168 and Gemmiza9 (Fig. 4).

Under saline irrigation, the cultivars were grouped into three major groups, in which the first group contained Sakha8, Misr2, and Sakha93. The second group included Sakha94, Gemmiza10, Giza168, Gimmiza9, Giza164, and Gemmiza7. The third group contains only Sakha61 (Fig. 4).



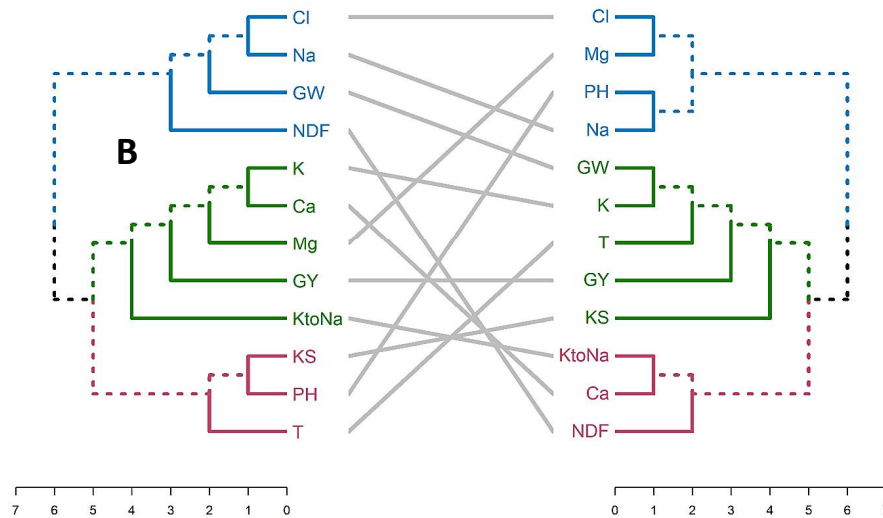

**Fig. 3. Effect of saline irrigation on the relationships among grain yield (GY ), number of fertile tillers (T), grain weight per spike (GW), Kernels per spike (KS), plant height (PH), number of days to flowering (NDF), Ca, K, Mg, Na, K/Na ratio (KtoNa) and Cl traits using dendrograms estimated from the genetic correlations among traits measured under control (0.5 dSm<sup>-1</sup>, A) and that measured under 9 dSm<sup>-1</sup> (B)**

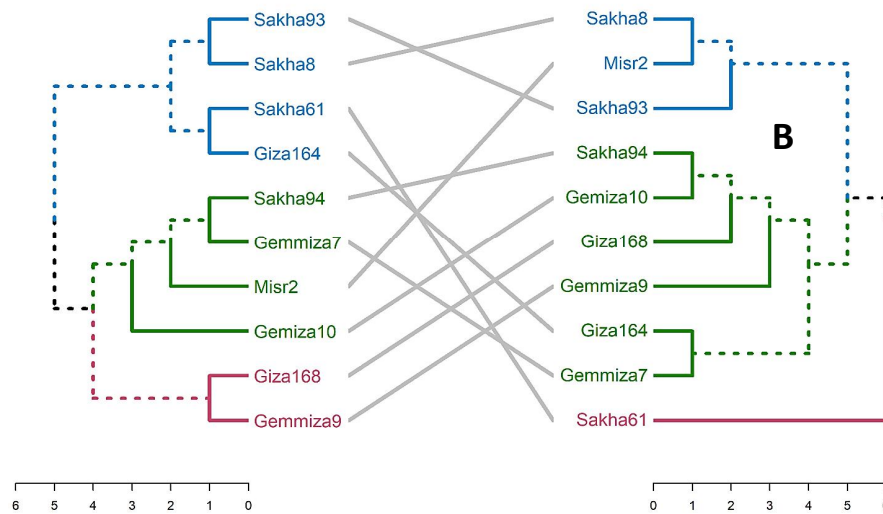

**Fig. 4. Effect of control (0.5 dSm<sup>-1</sup>, A) and saline irrigation (9 dSm<sup>-1</sup>, B) on the relationships among the studied cultivars using dendrograms estimated from the genetic correlations among cultivars for agronomic and physiological traits**

### 3.5 Cultivars Screening with SSR Markers

The screening results using the SSR markers indicated that only four markers were polymorphic across the ten cultivars. These four markers were *xgwm312* (Fig. 5), *Xcfd9*, *Xcfd46*, and *XWmc170*, which were present at 199, 210,

210, and 220 bp, respectively, in Skaha8, Misr2, and Sakaha93. Furthermore, *cslinkNax2* was not present in any of the studied cultivars. While *Xbarc128*, *Xwmc773*, *Xgwm674*, *Xbarc159*, and *Xgwm674* were present in all cultivars (Monomorphic markers).

### 3.6 Impact of Water Salinity Levels on the Tolerant and Sensitive Cultivars

Our results indicated that Misr2, Sakaha8, and Sakaha93 were found to be salinity stress-tolerant cultivars. Furthermore, seven cultivars (Gimmiza7, Gimmiza9, Gimmiza10, Giza164, Giza168, Sakah61, and Sakaha94) were sensitive to salinity stress. Thus, the salinity stress-tolerant cultivars were compared to the salinity stress-sensitive cultivars, based on the overall average performance across the four salinity levels (0.5, 5, 7, and 9 dSm<sup>-1</sup>) to measure the impact of saline irrigation on the studied traits (Table 1). The overall average across the four salinity levels indicated that the salinity stress-tolerant cultivars outperformed the sensitive ones by 5.6, 26.5, 17.6, 17.6 and 64.3% for the number of days to flowering, grain yield, number of fertile tillers, kernels per spike and grain weight per spike, respectively. Furthermore, at 0.5 dSm<sup>-1</sup>, the sensitive cultivars were better than the tolerant ones by 4.9, 5.7, 5.9 and 4.6% for plant height, grain yield, the number of tillers, and the number of kernels per spike. At five dSm<sup>-1</sup>, the salinity stress-tolerant cultivars outperformed the sensitive ones by 9.4, 28.6, 8.1, and 38.9 % for the number of days to flowering, grain yield, kernels per spike and grain weight per spike, respectively. However, at five dSm<sup>-1</sup>, the sensitive cultivars had 6.6 % more tillers compared to the tolerant cultivars (Table 1). At seven dSm<sup>-1</sup>, the number of days to flowering, grain yield, the number of fertile tillers, the number of kernels per spike, and the grain weight per spike were higher in the tolerant cultivars by 3.7, 54.3, 51.4, 54.5 and 175%,

respectively. Moreover, at nine dSm<sup>-1</sup>, the number of days to flowering, grain yield, the number of fertile tillers, the number of kernels per spike, and the grain weight per spike were higher in the tolerant cultivars by 2.5, 100, 130, 69.6, and 260%, respectively. While, the sensitive cultivars irrigated with 0.5, 5, 7, and 9 dSm<sup>-1</sup> of saline water were taller than the tolerant ones by 4.9, 5.6, 3.3, and 4.5 %, respectively (Table 1).

Additionally, the overall average across the four salinity levels for Ca<sup>+2</sup>, Mg<sup>+2</sup>, K<sup>+</sup>, Na<sup>+</sup>, Cl<sup>-</sup> and K/Na ratio concentrations in the salinity stress-tolerant cultivars were compared to that in the salinity stress-sensitive ones (Table 1). Overall, the concentrations of Ca<sup>+2</sup>, Mg<sup>+2</sup>, K<sup>+</sup> and K/Na ratio were higher in the salinity stress-tolerant cultivars by 17.6, 3.1, 67.9 and 175%, respectively. At 0.5 dSm<sup>-1</sup>, Ca<sup>+2</sup>, Mg<sup>+2</sup>, K<sup>+</sup> and K/Na ratio were higher in the tolerant cultivars by 2.2, 5.4, 13.6, and 92.3, respectively. Moreover, at five dSm<sup>-1</sup>, the concentrations of Ca<sup>+2</sup>, Mg<sup>+2</sup>, K<sup>+</sup>, and K/Na ratio were higher in the salinity stress-tolerant cultivars by 17.3, 1, 108.3, 266.7%, respectively (Table 1). At seven dSm<sup>-1</sup>, Ca<sup>+2</sup>, K<sup>+</sup>, and K/Na ratio were higher in the salinity stress-tolerant cultivars by 66.7, 121.3, and 400 %, respectively. Furthermore, at nine dSm<sup>-1</sup>, Ca<sup>+2</sup>, K<sup>+</sup>, and K/Na ratio were higher in the salinity stress-tolerant cultivars by 43.5, 256.5, and 200 %, respectively. On the other hand, the difference between the tolerant and the sensitive cultivars for Mg<sup>+2</sup> concentration at seven dSm<sup>-1</sup> reached zero. However, at nine dSm<sup>-1</sup>, the sensitive cultivars had 1.3% more Mg<sup>+2</sup> compared to the tolerant ones (Table 1).

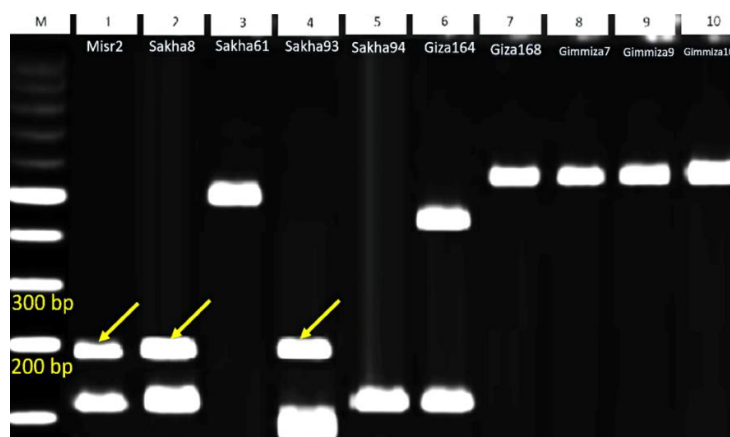

Fig. 5. PCR products on a 3% agarose gel for *xgwm312* marker across the ten wheat cultivars used

Nevertheless, the overall average across the four salinity levels for  $\text{Na}^+$  and  $\text{Cl}^-$  concentrations were higher in the sensitive cultivars by 55.1 and 26.5%, respectively. Furthermore,  $\text{Na}^+$  concentrations in the sensitive cultivars irrigated with 0.5, 5, 7, and 9  $\text{dSm}^{-1}$  were higher than that in the tolerant cultivars by 35.8, 52.8, 60.9, and 58.8%, respectively. Similarly,  $\text{Cl}^-$  concentrations in the sensitive cultivars irrigated with 0.5, 5, 7, and 9  $\text{dSm}^{-1}$  were higher than  $\text{Cl}^-$  concentrations in the tolerant cultivars by 26.4, 20.5, 33.1, and 25.4%, respectively. Our results also indicated that 6.25  $\text{dSm}^{-1}$  is the maximum saline water that can be used to irrigate the sensitive wheat cultivars (Fig. 6). In which 6.25  $\text{dSm}^{-1}$  is the salinity level that maximizes grain yield, the number of fertile tillers and  $\text{K}^+$  concentration while minimizing  $\text{Na}^+$  accumulation in plants. For the same reasons, nine  $\text{dSm}^{-1}$  or slightly above was defined as the salinity threshold for the salinity stress-tolerant cultivars (Fig. 6).

#### 4. DISCUSSION

Freshwater scarcity will be exacerbated as a result of the rapidly increasing human population and urbanization [49]. The gap between freshwater demand and availability has reached a critical point in several regions worldwide [50]. Using saline water in irrigation is one of the approaches that have been developed to address the freshwater gap [51,6,50]. The predominant salt source in the saline water is NaCl; non-saline water has a total salt concentration  $< 0.7 \text{ dSm}^{-1}$  [50]. Saline water in the range between 2 and 10  $\text{dSm}^{-1}$  has the potential to be used in irrigation [50]. Water with  $\text{EC} > 10 \text{ dSm}^{-1}$  is not recommended for irrigation, and water with  $\text{EC} < 10$  can be used in agriculture while carefully monitoring saline accumulation in the soil [50]. Plant tolerance to salinity is the essential factor in determining the usefulness of saline water. Several parameters can be used to measure the impact of salinity on plants. These parameters include growth, plant-water relations, photosynthesis, yield components, senescence and the accumulation of Na and Cl ions in plants that were grown in soil or irrigated with water that contained high NaCl concentrations [52,53,54]. In the current experiment, a control (non-saline water, 0.5  $\text{dSm}^{-1}$ ) and irrigation water with three NaCl concentrations, i.e., 5, 7, 9  $\text{dSm}^{-1}$ , were used to irrigate ten of the commercially grown wheat cultivars in pots placed in the open field.

Our results indicated that increasing salinity concentrations in the irrigation water substantially decreased the number of days to flowering, plant height, number of fertile tillers, grain yield, grain weight per spike and number of kernels per spike. Early flowering can be explained by the stress-induced early flowering phenomena in which plants grown under stress undergo several morphological, physiological, and biochemical changes to shorten the life cycle to produce seeds before stress leads to death [55]. Moreover, stressed wheat plants are found to mature earlier than their counterparts grown under optimal conditions [56]. However, grain yield reduction caused by shortening the grain filling period could not be counterbalanced by a higher filling rate [57]. Shorter wheat plants under salinity conditions is another trait that was a result of plant mechanisms to minimize water loss by reducing transpiration and, therefore, canopy area [52]. Also, reducing transpiration will keep a substantial amount of the toxic ions in roots and prevent its accumulation in the above-ground plant parts [52]. Furthermore, salinity stress also reduces stem elongation and growth, which resulted in shorter or stunted plants [58].

The importance of fertile tillers is evident from the fact that it directly affects the final grain yield. Furthermore, under salinity stress, the main stem was found to be less sensitive to salt stress compared to its tillers [57]. Several explanations were provided for the previous observation; reduction in carbohydrate supply caused by salinity in the tillers is more than that in the main stem, photosynthates are retained in the main stems rather than exporting it to their tillers [59]. Furthermore, the main stem tends to compete with the tillers to uptake nutrition to alleviate the impact of toxic ions present under salinity [57]. When plants undergo severe salinity stress during the reproductive stage, translocation of nutrients from the main stem to tillers will be interrupted [59,60,56]. Subsequently, seed setting in tillers will be affected [61]. Thus, tolerant wheat cultivars in our study tend to have more fertile tillers. Moreover, several researchers have demonstrated that fertile tillers number, leaf number and leaf area per plant were found to be among the key parameters that can be used to distinguish salinity tolerant wheat genotypes [61].

The grain yield of all cultivars used in the current study was generally higher when irrigated with non-saline water (0.5  $\text{dSm}^{-1}$ ) compare to those irrigated with any of the three levels of saline water (5, 7 or 9  $\text{dSm}^{-1}$ ) as expected.

**Table 1. The difference between salinity stress tolerant and sensitive cultivars across the physio-agronomical traits measured under each salinity level**

Salinity levels (dSm <sup>-1</sup> )	Morpho-agronomical				The tolerance effect (%)	Physiological			
	Trait	Cultivars		Trait		Cultivars		The tolerance effect (%)	
		Sensitive	Tolerant			Sensitive	Tolerant		
0.5	No. of days to flowering	105.4	111.7	6	Ca <sup>+2</sup>	13.9	14.2	2.2	
5		97.5	106.7	9.4		7.5	8.8	17.3	
7		84.6	87.7	3.7		3.3	5.5	66.7	
9		79.3	81.3	2.5		2.3	3.3	43.5	
Mean		91.7	96.8	5.6		Mean	6.8	8	17.6
0.5	Plant height	104.2	99.1	-4.9	Mg <sup>+2</sup>	13	13.7	5.4	
5		90	85	-5.6		9.9	10	1	
7		66.8	64.6	-3.3		8.5	8.5	0	
9		57.5	54.9	-4.5		7.6	7.5	-1.3	
Mean		79.6	75.9	-4.6		Mean	9.7	10	3.1
0.5	Grain yield	8.8	8.3	-5.7	K <sup>+</sup>	18.4	20.9	13.6	
5		4.9	6.3	28.6		7.2	15	108.3	
7		3.5	5.4	54.3		4.7	10.4	121.3	
9		2.4	4.8	100		2.3	8.2	256.5	
Mean		4.9	6.2	26.5		Mean	8.1	13.6	67.9
0.5	No. of tillers	8.5	8	-5.9	Na <sup>+</sup>	14.8	9.5	-35.8	
5		6.5	6.1	-6.2		25.4	12	-52.8	
7		3.5	5.3	51.4		35.8	14	-60.9	
9		2	4.6	130		38.8	16	-58.8	
Mean		5.1	6	17.6		Mean	28.7	12.9	-55.1
0.5	No. of kernels per spike	8.7	8.3	-4.6	Cl <sup>-</sup>	12.9	9.5	-26.4	
5		6.2	6.7	8.1		13.2	10.5	-20.5	
7		3.3	5.1	54.5		17.5	11.7	-33.1	
9		2.3	3.9	69.6		18.5	13.8	-25.4	
Mean		5.1	6	17.6		Mean	15.5	11.4	-26.5
0.5	Grain wt. per spike	2.3	2.7	17.4	K/Na ratio	1.3	2.5	92.3	
5		1.8	2.5	38.9		0.3	1.1	266.7	
7		0.8	2.2	175		0.1	0.5	400	
9		0.5	1.8	260		0.1	0.3	200	
Mean		1.4	2.3	64.3		Mean	0.4	1.1	175

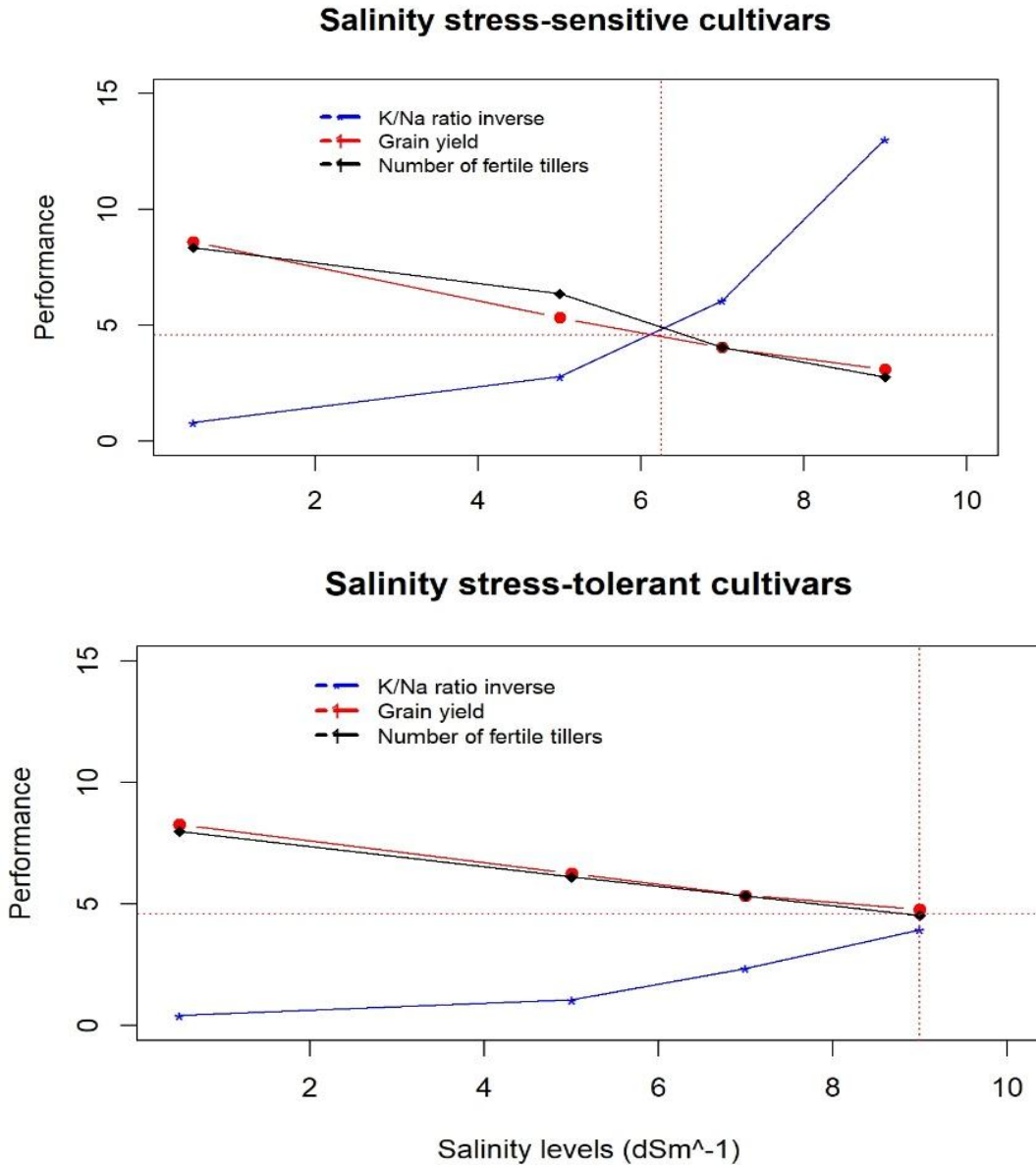

**Fig. 6. The Estimated salinity threshold level that maximizes grain yield, the number of fertile tillers, and K<sup>+</sup> while minimizing Na<sup>+</sup> accumulation for the salinity stress-sensitive and tolerant wheat cultivars**

The trend of grain yield reduction across different levels of salt stress indicated that the yield reduction increased with increasing salinity levels. Grain yield and its contributing traits measured were drastically affected by the presence of salts in the irrigation water. Overall, wheat grain yield potential is determined mainly by three parameters: The number of spikes per

unit area, kernel number spike<sup>-1</sup>, and single kernel weight [62]. Salinity stress can affect the final grain yield by decreasing the number of spikes, i.e., by reducing the number of fertile tillers, impair fertilization because of floret or pollen sterility, and increasing the abortion rate for the fertilized grains [63], thus reducing kernels per spike.

In addition, kernel weight in wheat is determined by the rate and duration of grain filling period in which assimilates transportation takes place [57]. Under dryland conditions, assimilate reserves have a greater contribution to grain filling during the grain filling period than ongoing photosynthesis [64,65]. Therefore, when salinity stress occurs after anthesis, grain filling becomes more dependent on the dry matter mobilization from stem reserves [65]. The stem stored carbohydrate is positively correlated with plant height in wheat [66]. Given that the cultivars used in the current study contain salinity stress-sensitive, moderately tolerant, and tolerant cultivars, it was expected that the cultivars would not follow the same trend in mobilizing the stored carbohydrate from the stem under saline conditions. Therefore, the stem's mobilization process might explain the observed relationship between plant height and grain yield, in which plant height was correlated with grain yield under non-saline irrigation only.

In the current study  $6.25 \text{ dSm}^{-1}$  found to be the salinity threshold for sensitive cultivars. Our estimated threshold is  $0.25 \text{ dSm}^{-1}$  higher than the previously reported, in which it was estimated that six  $\text{dSm}^{-1}$  of salinity is the wheat threshold [19]. The difference between our estimation and previous reports could be attributed to using different cultivars and growing plant materials in different environmental conditions. Overall, it was estimated that grain yield would be reduced by 7.1% for each  $\text{dSm}^{-1}$  increase above the threshold [19]. Under salinity stress, grain yield reduction was observed as a result of the negative impact of salinity on the spikes number per plant, spike length, the number of spikelets per spike, straw weight, grain yield, 1000-grain weight, and harvest index [36,67,19]. Understanding the adaptive physiological responses of wheat plants to salinity stress will assist breeders in identifying critical physiological processes for salinity stress tolerance. Thus, salinity stress evaluation has shifted towards examining specific physiological traits involved in salt tolerance, i.e., cation and anion absorption [68].

Throughout the growing seasons, plants in the current experiment were irrigated with non-saline water ( $0.5 \text{ dSm}^{-1}$ ) or three levels of saline water (5, 7 or  $9 \text{ dSm}^{-1}$ ). Across the four salinity levels, the tolerant cultivars had lower flag leaf  $\text{Na}^+$  and  $\text{Cl}^-$  concentrations, while they had higher concentrations of  $\text{K}^+$ ,  $\text{Mg}^{+2}$ ,  $\text{Ca}^{+2}$ , and K/Na ratio compared to the sensitive cultivars. K/Na ratio was significantly correlated with grain yield under

saline and non-saline irrigation. Furthermore, none of the studied traits under non-saline irrigation other than grain yield was correlated with K/Na ratio. In contrast, under saline irrigation, all traits, including grain yield, were significantly associated with K/Na ratio. The correlation relationship observed between K/Na ratio and the studied traits could be attributed to the small value of K/Na ratio under non-saline irrigation. While, under salinity, plants uptake a larger quantity of Na; therefore, K/Na ratio can be used as an indicator for either sodium or potassium uptake [69]. K/Na ratio can also be used to distinguish salinity tolerant from sensitive plants [69].

The observed differences among the studied cultivars for the physio-agronomical traits studied could be attributed to efficient osmotic adjustment in the tolerant cultivars due to their higher K/Na ratio compared to the sensitive ones. K/Na ratio has become an essential salinity stress tolerance trait [18]. For example, bread wheat tolerance to salinity is characterized by higher  $\text{K}^+$  to  $\text{Na}^+$  uptake [18]. Maintaining a high K/Na ratio is critical in preserving cell volume regulation under salt stress, which is found to increase salt tolerance in wheat [39]. In bread wheat, a locus (Kna1) on the 4D chromosome was found to be associated with  $\text{Na}^+$  accumulation and the K/Na ratio [70]. Furthermore, to improve bread wheat capacity to restrict Na accumulation in leaves, two major genes for Na exclusion, *Nax1*, and *Nax2*, were transferred from durum wheat into bread wheat.

Our results also indicated a negative impact of  $\text{Na}^+$  accumulation on  $\text{Ca}^{+2}$  and  $\text{Mg}^{+2}$ . In contrast, the salinity stress-tolerant cultivars tend to contain higher concentrations of  $\text{Ca}^{+2}$  and  $\text{Mg}^{+2}$  compared to the sensitive cultivars. This result agrees with previous research [17,71,3]. The observed differences among salinity stress tolerant and sensitive cultivars could also be due to the alleviation effect of  $\text{Ca}^{+2}$  on  $\text{Na}^+$  accumulation [71].  $\text{Ca}^{+2}$  may preserve the selective ability of the cell membrane under saline conditions [72].

Furthermore, high saline soil solution was found to displace  $\text{Ca}^{+2}$  from the root cells, causing  $\text{Ca}^{+2}$  deficiencies [72]. Moreover, under saline irrigation treatment,  $\text{Mg}^{+2}$  was found to be negatively correlated with  $\text{Cl}^-$ , while it was not associated with  $\text{Ca}^{+2}$ . However, under non-saline irrigation,  $\text{Mg}^{+2}$  and  $\text{Ca}^{+2}$  were significantly correlated. Additionally, under non-saline irrigation,  $\text{Mg}^{+2}$  was associated with all traits

except the number of days to flowering and the number of fertile tillers. Saline irrigation impacted the relationships between  $Mg^{+2}$  with  $Ca^{+2}$  and that between  $Ca^{+2}$  and  $Mg^{+2}$  with the phenotypical and agronomical traits studied. A possible explanation for the previous findings might be saline irrigation's effect on increasing the mobility of  $Mg^{+2}$  and  $Ca^{+2}$ . In which  $Mg^{+2}$  and  $Ca^{+2}$  were found to be easily leached down as  $Na^{+}$  concentration in the soil solution increases [73]. Furthermore,  $Mg^{+2}$  and  $Ca^{+2}$  uptake by plants from the soil solution can be reduced as a result of the ionic competition for the roots absorption sites [74]. Thus, under saline irrigation, the concentration of  $Ca^{+2}$  and  $Mg^{+2}$  was decreased because of the increased ionic strength of the soil solution and eventually reduced plant growth and yield.

The phenotypic and physiological measurements clustered the salinity stress-tolerant cultivars (Sakaha8, Misr2, and Sakah93) in a single cluster. Similar results were also obtained from the SSR markers screening in which *xgwm312*, *Xcfd9*, *Xcfd46*, and *XWmc170* were present only in the salinity stress-tolerant cultivars. Furthermore, *Xgwm312* is known to be associated with *Nax1* locus [75,18,76]. *Nax1* is located on chromosome 2A linked to the salinity stress tolerance quantitative trait locus (QTL) and was associated with Na transporter of the HKT gene family HKT7 [75].

Nevertheless, the *Xgwm312* marker was found to be correlated with  $\alpha$ -amylase activity and water uptake during the seedling stage in spring wheat grown under salinity stress [76]. However, the presence of the *Xgwm312* SSR marker in the spring wheat cultivars used in this study was unexpected since the marker is linked with *Nax1* locus in some durum wheat genotypes. Hence it should not be present in the modern bread wheat [75]. An explanation of *Xgwm312* presence in the modern bread wheat used in the current experiment could be attributed to the existence of *Nax1* analogous gene/s that might occupy the same locus with *Nax1*. Overall, the results reported in the present experiment confirmed that  $Na^{+}$  and  $Cl^{-}$  exclusion is a critical factor in wheat tolerance for salinity stress.

Depending on the growth stage and parts of the plant used in the analysis, the ranges of the optimum nutrient levels for cereal crops were developed [77]. That ranges are from 1.5 to 20  $mg\ g^{-1}$  for  $Ca^{+2}$ , from 1 to 12  $mg\ g^{-1}$  for  $Mg^{+2}$ , and from 15 to 23  $mg\ g^{-1}$  for  $K^{+}$ . The estimated  $Ca^{+2}$ ,  $Mg^{+2}$ , and  $K^{+}$  under non-saline irrigation in the

current study fall into these ranges. However, as salinity increased, so did the reduction of  $Ca^{+2}$ ,  $Mg^{+2}$ , and  $K^{+}$  increase. The highest reduction, (and the maximum shortfall) was recorded under the highest saline irrigation level used. Even though the salinity stress-tolerant cultivars were injured by  $Ca^{+2}$ ,  $Mg^{+2}$ , and  $K^{+}$  deficiencies, their injuries were less than those of the sensitive cultivars in sustaining relatively higher concentrations of  $Ca^{+2}$ ,  $Mg^{+2}$ , and  $K^{+}$ . Clearly, accumulated  $Na^{+}$  and  $Cl^{-}$  in the leaf blade under saline irrigation increased  $Ca^{+2}$ ,  $Mg^{+2}$ , and  $K^{+}$  deficiency. It was also observed from pre-planting and post-harvesting soil analysis that because of irrigation with nine  $dSm^{-1}$ , soil salinity was increased by 79.77% on average across the two growing seasons. The Soil pH was decreased by 3.8%. Similarly,  $K^{+}$ ,  $Ca^{+2}$ ,  $Mg^{+2}$ ,  $Na^{+}$ , and  $Cl^{-}$  concentrations were also increased as the level of saline water increased. Overall, using saline irrigation increased soil salinity and leachability of  $Mg^{+2}$ ,  $K^{+}$ , and  $Ca^{+2}$ . Similar results were previously reported in which saline irrigation significantly increased salinity,  $Na^{+}$ , and  $Cl^{-}$  in the post-harvest soils by increasing the leachability of  $K^{+}$ ,  $Ca^{+2}$ , and  $Mg^{+2}$  from the soil [73].

## 5. CONCLUSION

Using saline water in irrigation requires appropriate and careful management to ensure sustainable agriculture and minimizing salt build up in the soil profile. Saline water dramatically reduced grain yield and its attributed traits. However, salinity stress-tolerant cultivars tend to be less affected by saline irrigation compared to the sensitive ones. Utilizing nine  $dSm^{-1}$  of saline water in irrigation reduced grain yield by 63.9% on average across all cultivars and growing seasons. Overall, the average performance of the salinity stress-tolerant cultivars across the levels of saline water used was 26.5% better than the sensitive ones for grain yield. However, under nine  $dSm^{-1}$  the tolerant cultivars were two-fold better than the sensitive ones. Moreover, under nine  $dSm^{-1}$ , the tolerant cultivars had 130% more fertile tillers, 260% higher kernel weight per spike, 200% higher K/Na ratio and 43.5% more  $Ca^{+2}$  compared to the sensitive ones. Giving the tremendous yield reduction experienced by both tolerant and sensitive wheat cultivars used in the current study, we recommend the following: a) pyramiding *Nax1* and *Nax2* genes in the breeders' elite lines that meant to be grown in a saline environment, b) new fertilizers recommendations need to be developed to address  $Ca^{+2}$  and  $K^{+}$  deficiencies under saline environments, c) seed rate by the unit area under

salinity conditions need to be considered to substitute tillers reduction by more seeds per unit area, d) the long term impact of saline irrigation on soil sustainability and crop production needs to be further investigated.

## AVAILABILITY OF DATA AND MATERIALS

All data supporting the findings of this study are available in the article or its Supplementary Information.

## FUNDING

This study is supported by the Science and Technology Development Fund (STDF), Egypt, grant No. 14935.

## COMPETING INTERESTS

Authors have declared that no competing interests exist.

## REFERENCES

- Shrivastava P, Kumar R. Soil salinity: A serious environmental issue and plant growth promoting bacteria as one of the tools for its alleviation. Elsevier; 2015. DOI: 10.1016/j.sjbs.2014.12.001
- Zaman M, Shahid SA, Heng L, Shahid SA, Zaman M, Heng L. "Soil salinity: Historical perspectives and a world overview of the problem," in guideline for salinity assessment, mitigation and adaptation using nuclear and related techniques (springer international publishing). 2018;43–53. DOI: 10.1007/978-3-319-96190-3\_2
- Genc Y, Taylor J, Lyons G, Li Y, Cheong J, Appelbee M et al. Bread Wheat With High Salinity and Sodicyty Tolerance. Front. Plant Sci. 2019;10:1280. DOI: 10.3389/fpls.2019.01280
- Singh P, Mahajan MM, Singh NK, Kumar D, Kumar K.. Physiological and molecular response under salinity stress in bread wheat (*Triticum aestivum* L.). J. Plant Biochem. Biotechnol. 2020;29:125–133. DOI: 10.1007/s13562-019-00521-3
- Dadshani S, Sharma RC, Baum M, Ogbonnaya FC, Léon J, Ballvora A. Multi-dimensional evaluation of response to salt stress in wheat. PLoS One. 2019;14:e0222659. DOI: 10.1371/journal.pone.0222659
- Mancosu N, Snyder RL, Kyriakakis G, Spano D. Water scarcity and future challenges for food production. Water (Switzerland). 2015;7:975–992. DOI: 10.3390/w7030975
- Kotb TH, Watanabe T, Ogino Y, Tanji KK. Soil salinization in the Nile delta and related policy issues in Egypt. Agric. Water Manag. 2000;43:239–261. DOI: 10.1016/S0378-3774(99)00052-9
- Hamam KA, Negim O. Evaluation of wheat genotypes and some soil properties under saline water irrigation. Ann. Agric. Sci. 2014;59:165–176. DOI: 10.1016/j.aos.2014.11.002
- Ghassemi F, Jakeman AJ, Nix HA. Salinisation of land and water resources: Human causes, extent, management and case studies. CAB international; 1995.
- Ayars JE, McWhorter DB. Incorporating crop water use in drainage design in arid areas. American Society of Civil Engineers; 1985.
- Ayars JE. Managing irrigation and drainage systems in arid areas in the presence of shallow groundwater: Case studies. Irrig. Drain. Syst. 1996;10:227–244. DOI: 10.1007/BF01102808
- Hanin M, Ebel C, Ngom M, Laplaze L, Masmoudi K. New insights on plant salt tolerance mechanisms and their potential use for breeding. Front. Plant Sci. 2016;7. DOI: 10.3389/fpls.2016.01787
- Munns R, Tester M. Mechanisms of Salinity Tolerance. Annu. Rev. Plant Biol. 2008;59:651–681. DOI:10.1146/annurev.arplant.59.032607.092911
- Kamran M, Parveen A, Ahmar S, Malik Z, Hussain S, Chattha MS et al.. An overview of hazardous impacts of soil salinity in crops, tolerance mechanisms, and amelioration through selenium supplementation. Int. J. Mol. Sci. 2020; 21. DOI: 10.3390/ijms21010148
- Tavakkoli E, Rengasamy P, McDonald GK. High concentrations of Na<sup>+</sup> and Cl<sup>-</sup> ions in soil solution have simultaneous detrimental effects on growth of faba bean under salinity stress. J. Exp. Bot. 2010;61:4449–4459. DOI:10.1093/jxb/erq251.
- Wu H. Plant salt tolerance and Na<sup>+</sup> sensing and transport. Crop J. 2018;6:215–225. DOI: 10.1016/j.cj.2018.01.003



17. Manchanda G, Garg N. Salinity and its effects on the functional biology of legumes. *Acta Physiol. Plant.* 2008;30:595–618.  
DOI: 10.1007/s11738-008-0173-3
18. Assaha DVM, Ueda A, Saneoka H, Al-Yahyai R, Yaish MW. The role of Na<sup>+</sup> and K<sup>+</sup> transporters in salt stress adaptation in glycophytes. *Front. Physiol.* 2017;8:509.  
DOI: 10.3389/fphys.2017.00509
19. Hasanuzzaman M, Nahar K, Rahman A, Anee TI, Alam MU, Bhuiyan TF et al. "Approaches to enhance salt stress tolerance in wheat," in wheat improvement, management and utilization (intech); 2017.  
DOI: 10.5772/67247
20. Hernández JA. Salinity tolerance in plants: Trends and perspectives. *Int. J. Mol. Sci.* 2019;20.  
DOI: 10.3390/ijms20102408
21. Naylor D, Coleman-Derr D. Drought Stress and Root-Associated Bacterial Communities. *Front. Plant Sci.* 2018;8:2223.  
DOI: 10.3389/fpls.2017.02223
22. Jenks MA, Hasegawa PM, Jain SM. Advances in molecular breeding toward drought and salt tolerant crops. Springer Netherlands; 2007.  
DOI: 10.1007/978-1-4020-5578-2
23. Läuchli A, Grattan SR. "Plant growth and development under salinity stress," in advances in molecular breeding toward drought and salt tolerant crops (Springer Netherlands). 2007;1–32.  
DOI: 10.1007/978-1-4020-5578-2\_1
24. Saddiq MS, Afzal I, Basra SMA, Iqbal S, Ashraf M. Sodium exclusion affects seed yield and physiological traits of wheat genotypes grown under salt stress. *J. Soil Sci. Plant Nutr.* 2020;1-15.  
DOI: 10.1007/s42729-020-00224-y
25. Fariduddin Q, Mir BA, Ahmad A. Physiological and biochemical traits as tools to screen sensitive and resistant varieties of tomatoes exposed to salt stress. *Brazilian J. Plant Physiol.* 2012;24:281–292.  
DOI:10.1590/S1677-04202012000400007
26. Herrmann H, Bucksch H. "Soil salinization," in dictionary geotechnical engineering/wörterbuch geotechnik. 2014;1268–1268.  
DOI: 10.1007/978-3-642-41714-6\_195352
27. Santos Pereira L, Cordery I, Iacovides I. Coping with water scarcity: Addressing the challenges. Springer Netherlands; 2009.  
DOI: 10.1007/978-1-4020-9579-5
28. Feng G, Zhang Z, Zhang Z. Evaluating the sustainable use of salinewater irrigation on soil water-salt content and grain yield under subsurface drainage condition. *Sustain.* 2019;11.  
DOI: 10.3390/su11226431
29. Munns R, James RA, Läuchli A. Approaches to increasing the salt tolerance of wheat and other cereals. In *Journal of Experimental Botany.* 2006:1025–1043.  
DOI: 10.1093/jxb/erj100
30. Heydari N. Water productivity improvement under salinity conditions: Case study of the saline areas of lower karkheh river basin, Iran. In *Multifunctionality and Impacts of Organic and Conventional Agriculture (IntechOpen)*; 2020.  
DOI: 10.5772/intechopen.86891
31. van der Zee, SEATM, Stofberg SF, Yang X, Liu Y, Islam MN, Hu YF. Irrigation and drainage in agriculture: A salinity and environmental perspective. In *Current Perspective on Irrigation and Drainage (Intech)*; 2017.  
DOI: 10.5772/66046
32. Forero LE, Grenzer J, Heinze J, Schittko C, Kulmatiski A. Greenhouse and field-measured plant-soil feedbacks are not correlated. *Front. Environ. Sci.* 2019;7.  
DOI: 10.3389/fenvs.2019.00184
33. Tavakkoli E. Limitations to yield in saline-sodic soils: Quantification of the osmotic and ionic regulations that affect the growth of crops under salinity stress. *Transport*; 2011.  
Available:<https://digital.library.adelaide.edu.au/dspace/handle/2440/70293>
34. Kakar N, Jumaa SH, Redoña ED, Warburton ML, Reddy KR. Evaluating rice for salinity using pot-culture provides a systematic tolerance assessment at the seedling stage. *Rice.* 2019;12:57.  
DOI: 10.1186/s12284-019-0317-7
35. Shannon MC. Adaptation of plants to salinity. *Adv. Agron.* 1997;60:75–120.  
DOI: 10.1016/S0065-2113(08)60601-X
36. Chinnusamy V, Jagendorf A, Zhu JK. Understanding and improving salt tolerance in plants. In *Crop Science.* 2005;437–448.  
DOI: 10.2135/cropsci2005.0437.
37. El-Hendawy SE, Hassan WM, Al-Suhaibani NA, Refay Y, Abdella KA. Comparative performance of multivariable agro-physiological parameters for detecting salt tolerance of wheat cultivars

- under simulated saline field growing conditions. *Front. Plant Sci.* 2017;8. DOI: 10.3389/fpls.2017.00435
38. Yassin M, El Sabagh A, Mekawy AMM, Islam MS, Hossain A, Barutcular C et al. Comparative performance of two bread wheat (*Triticum Aestivum* L.) genotypes under salinity stress. *Appl. Ecol. Environ. Res.* 2019;17:5029–5041. DOI: 10.15666/aeer/1702\_50295041
  39. El-Hendawy S, Al-Suhaibani N, Elsayed S, Alotaibi M, Hassan W, Schmidhalter U.. Performance of optimized hyperspectral reflectance indices and partial least squares regression for estimating the chlorophyll fluorescence and grain yield of wheat grown in simulated saline field conditions. *Plant Physiol. Biochem.* 2019a;144:300–311. DOI: 10.1016/j.plaphy.2019.10.006
  40. Gadallah A, Milad I, Yossef YA, Gouda MA. Evaluation of some egyptian bread wheat (*Triticum aestivum* ) cultivars under salinity stress; 2017.
  41. Staff soil survey. Keys to soil taxonomy. 12Ed. United States Dep. Agric. Nat. Resour. Conserv. Serv. Lincoln. 2014;97:123-287.
  42. Krishnasamy K, Bell R, Ma Q. Wheat responses to sodium vary with potassium use efficiency of cultivars. *Front. Plant Sci.* 2014;5:1–10. DOI: 10.3389/fpls.2014.00631
  43. Federer WT, King F. Variations on split plot and split block experiment designs. John wiley & Sons: New York, NY, USA; 2006. DOI: 10.1002/0470108584
  44. Steel RGD, Torrie JH. Principles and procedures of statistics: A biometrical approach. 2<sup>nd</sup> Ed. McGraw-Hill Publishing Co., New York; 1980.
  45. Cochran WG, Cox GM. Experimental Designs. 2d Ed. Wiley, New York; 1957.
  46. Mendiburu F de, Gomez KA, Gomez AA, Gomez KA. Statistical procedures for agricultural research. 1984;680. Available: <https://www.wiley.com/eneg/Statistical+Procedures+for+Agricultural+Research,+2nd+Edition-p-9780471870920> [Accessed January 23, 2018]
  47. Alvarado G, Rodríguez FM, Pacheco A, Burgueño J, Crossa J, Vargas M et al. META-R: A software to analyze data from multi-environment plant breeding trials. *Crop J.* 2020;8:745–756. DOI: 10.1016/j.cj.2020.03.010
  48. Ward JH. Hierarchical grouping to optimize an objective function. *J. Am. Stat. Assoc.* 1963;58:236–244. DOI: 10.1080/01621459.1963.10500845
  49. Boretti A, Rosa L. Reassessing the projections of the world water development report. *npj Clean Water.* 2019;2:1–6. DOI: 10.1038/s41545-019-0039-9
  50. Velmurugan A, Swarnam P, Subramani T, Meena B, Kaledhonkar MJ. “water demand and salinity,”. In *Desalination - Challenges and Opportunities* [working title] (IntechOpen); 2020. DOI: 10.5772/intechopen.88095
  51. Siebert S, Burke J, Faures JM, Frenken K, Hoogeveen J, Döll P et al. Groundwater use for irrigation - a global inventory. *Hydrol. Earth Syst. Sci.* 2010;14:1863–1880. DOI: 10.5194/hess-14-1863-2010
  52. Acosta-Motos JR, Ortuño MF, Bernal-Vicente A, Diaz-Vivancos P, Sanchez-Blanco MJ, Hernandez JA. Plant responses to salt stress: Adaptive mechanisms. *Agronomy.* 2017;7:18. DOI: 10.3390/agronomy7010018
  53. Ji C, Mao X, Hao J, Wang X, Xue J, Cui H et al. Analysis of bZIP transcription factor family and their expressions under salt stress in *Chlamydomonas reinhardtii*. *Int. J. Mol. Sci.* 2018;19. DOI: 10.3390/ijms19092800
  54. Wang N, Qian Z, Luo M, Fan S, Zhang X, Zhang L. Identification of salt stress responding genes using transcriptome analysis in green alga *chlamydomonas reinhardtii*. *Int. J. Mol. Sci.* 2018;19. DOI: 10.3390/ijms19113359
  55. Kazan K, Lyons R. The link between flowering time and stress tolerance. *J. Exp. Bot.* 2016;67:47–60. DOI: 10.1093/jxb/erv441
  56. Hütsch BW, Jahn D, Schubert S. Grain yield of wheat (*Triticum aestivum* L.) under long-term heat stress is sink-limited with stronger inhibition of kernel setting than grain filling. *J. Agron. Crop Sci.* 2019;205:22–32. DOI: 10.1111/jac.12298
  57. Ruan Y, Hu Y, Schmidhalter U. Effect of tiller removal on ion content in mainstem and subtillers of spring wheat under moderate salinity. *J. Plant Nutr.* 2012;35:1314–1328. DOI: 10.1080/01904167.2012.684124

58. Alarcón JJ, Morales MA, Ferrández T, Sánchez-Blanco MJ. Effects of water and salt stresses on growth, water relations and gas exchange in *Rosmarinus officinalis*. *J. Hortic. Sci. Biotechnol.* 2006;81:845–853.  
DOI: 10.1080/14620316.2006.11512148
59. Thorne GN. Distribution between parts of the main shoot and the tillers of photosynthate produced before and after anthesis in the top three leaves of main shoots of Hobbit and Maris Huntsman winter wheat. *Ann. Appl. Biol.* 1982;101:553–559.  
DOI: 10.1111/j.1744-7348.1982.tb00858.x
60. Tian Z, Li J, Jia X, Yang F, Wang Z. Assimilation and translocation of dry matter and phosphorus in rice genotypes affected by salt-alkaline stress. *Sustain.* 2016;8.  
DOI: 10.3390/su8060568
61. Ruan Y, Hu Y, Schmidhalter U. Insights on the role of tillering in salt tolerance of spring wheat from detillering. *Environ. Exp. Bot.* 2008;64:33–42.  
DOI: 10.1016/j.envexpbot.2008.04.004
62. Fischer RA. The importance of grain or kernel number in wheat: A reply to sinclair and jamieson. *F. Crop. Res.* 2008;105:15–21.  
DOI: 10.1016/j.fcr.2007.04.002
63. Dreccer MF, Wockner KB, Palta JA, McIntyre CL, Borgognone MG, Bourgault M et al. More fertile florets and grains per spike can be achieved at higher temperature in wheat lines with high spike biomass and sugar content at booting. *Funct. Plant Biol.* 2014;41:482–495.  
DOI: 10.1071/FP13232
64. Blum A. Improving wheat grain filling under stress by stem reserve mobilisation. In *Euphytica* (Kluwer Academic Publishers). 1998;77–83.  
DOI: 10.1023/a:1018303922482
65. Srivastava A, Srivastava P, Sharma A, Sarlach RS, Bains NS. Effect of stem reserve mobilization on grain filling under drought stress conditions in recombinant inbred population of wheat. *J. Appl. Nat. Sci.* 2017;9:1–5.  
DOI: 10.31018/jans.v9i1.1137
66. Hippolyte I, Jenny C, Gardes L, Bakry F, Rivallan R, Pomies V et al. Foundation characteristics of edible musa triploids revealed from allelic distribution of SSR markers. *Ann. Bot.* 2012;109:937–951.  
DOI: 10.1093/aob.c
67. Asgari HR, Cornelis W, Van Damme P. Salt stress effect on wheat (*Triticum aestivum* L.) growth and leaf ion concentrations. *Int. J. Plant Prod.* 2012;6:195–208.  
DOI: 10.22069/ijpp.2012.775
68. Kim S, Park M, Yeom SI, Kim YM, Lee JM, Lee HA, Seo E, Choi J, Cheong K, Kim KT, Jung K. Genome sequence of the hot pepper provides insights into the evolution of pungency in *Capsicum* species. *Nature Genetics.* 2014;46(3):270–8.
69. Asch F, Dingkuhn M, Dörffling K, Miezian K. Leaf K/Na ratio predicts salinity induced yield loss in irrigated rice. *Euphytica.* 2000;113:109–118.  
DOI: 10.1023/A:1003981313160
70. Dubcovsky J, Santa María G, Epstein E, Luo MC, Dvořák J. Mapping of the K<sup>+</sup>/Na<sup>+</sup> discrimination locus *Kna1* in wheat. *Theor. Appl. Genet.* 1996;92:448–454.  
DOI: 10.1007/BF00223692
71. Akter M, Oue H. Effect of saline irrigation on accumulation of Na<sup>+</sup>, K<sup>+</sup>, Ca<sup>2+</sup>, and Mg<sup>2+</sup> ions in rice plants. *Agric.* 2018;8.  
DOI: 10.3390/agriculture8100164
72. Ehret DL, Redmann RE, Harvey BL, Cipywnyk A. Salinity-induced calcium deficiencies in wheat and barley. *Plant Soil.* 1990;128:143–151.  
DOI: 10.1007/BF00011103
73. Hussain Z, Khattak RA, Irshad M, Mahmood Q, An P. Effect of saline irrigation water on the leachability of salts, growth and chemical composition of wheat (*Triticum aestivum* L.) in saline-sodic soil supplemented with phosphorus and potassium. *J. Soil Sci. Plant Nutr.* 2016;16:604–620.  
DOI: 10.4067/s0718-95162016005000031
74. Griffiths M, York LM. Targeting root ion uptake kinetics to increase plant productivity and nutrient use efficiency1[open]. *Plant Physiol.* 2020;182:1854–1868.  
DOI: 10.1104/PP.19.01496
75. Huang S, Spielmeier W, Lagudah ES, James RA, Platten JD, Dennis ES et al. A sodium transporter (HKT7) is a candidate for *Nax1*, a gene for salt tolerance in durum wheat. *Plant Physiol.* 2006;142:1718–1727.  
DOI: 10.1104/pp.106.088864
76. El-Hendawy S, Elshafei A, Al-Suhaibani N, Alotabi M, Hassan W, Dewir YH et al. Assessment of the salt tolerance of wheat

genotypes during the germination stage based on germination ability parameters and associated SSR markers. J. Plant Interact. 2019b;14:151–163.  
DOI: 10.1080/17429145.2019.1603406

77. Mee CY, Balasundram SK, Mohd Hanif AH. Detecting and monitoring plant nutrient stress using remote sensing approaches: A review. Asian J. Plant Sci. 2017;16:1–8.  
DOI: 10.3923/ajps.2017.1.8

---

© 2021 Morsy et al.; This is an Open Access article distributed under the terms of the Creative Commons Attribution License (<http://creativecommons.org/licenses/by/4.0>), which permits unrestricted use, distribution, and reproduction in any medium, provided the original work is properly cited.

*Peer-review history:*  
*The peer review history for this paper can be accessed here:*  
<http://www.sdiarticle4.com/review-history/65526>